

PFN

Proximal Femoral Nail System
Surgical Technique



Table of contents

Introduction

Preface	2
Features and Benefits	3
Indications	4

Surgical Technique

Preparation	5
Opening of the femur	6
Insertion of PFN	8
Insertion of blade or lag screw	9
Distal locking	15
Insertion of end cap	17
Implant removal	18
Cleaning	19

Product information

Implants	20
Tools	21

Warning

This description is not sufficient for immediate application of the instrumentation. Instruction by a surgeon experienced in handling this instrumentation is highly recommended.

Preface

With the increasing of aging population and high-energy injury, occurrence rate of trochanter fracture is increasing. Some elderly patients who perform the traditional therapy will hardly recover, and also lying in bed for long time will result in trochanter varus and other complications. Therefore early surgery is considered the efficient way for reducing complications and improving life quality.

Young patients and patients with good bone condition can perform the early surgery, which is the efficient way to reduce complications such as femur necrosis, malunion and so on.

Currently, implants therapy performed for trochanter fracture has the problem of large wound, long operation time and much more complications.

CanPFN offers two kinds of proximal fixation, which can not only offer stable fixation for elderly patients and osteoporosis patients, but also can offer dynamic fixation for young patients and patients with good bone condition.



Product Features

Product design philosophy:

Biomechanical stability fixation

Minimally invasive operation technology

Features and Benefits:

- Two functions achieved : anti-rotation and stable fixation
- Two interlocking options:
 - a. Helical blade: fill interspace to reduce bone loss.
 - b. Lag screw: offer better compression locking effect
- Long nail tip and flutes design to prevent stress concentration
- Medial-lateral angle of 5°.
- Inner thread design on the end of the nail makes easier for nail extracting.
- End cap with different heights.



Distal locking selected (Standard nail)



Static state Static state (90°) Dynamic

Distal locking select (Long nail)



Static state Dynamic

Indications

Indications:

Standard PFN(170mm-240mm)

- Petrochanteric fractures(31-A1 and 31-A2)
- Intertrochanteric fractures(31-A3)
- High subtrochanteric fractures(32-A1)



Indications:

PFN Long (length 360mm-420mm)

- Low and extended subtrochanteric fractures
- Ipsilateral trochanteric fractures
- Combination fractures(in the proximal femoral)
- Pathological fractures



Preparation

Preparation:

1. Determine nail diameter

Determine the nail diameter and length, distal locking screw length by an AP X-ray, or alternatively using the C-arm fluoroscopy and Radiographic Ruler (115400017) to determine nail diameter.

Instrument:

115400017 Radiographic Ruler

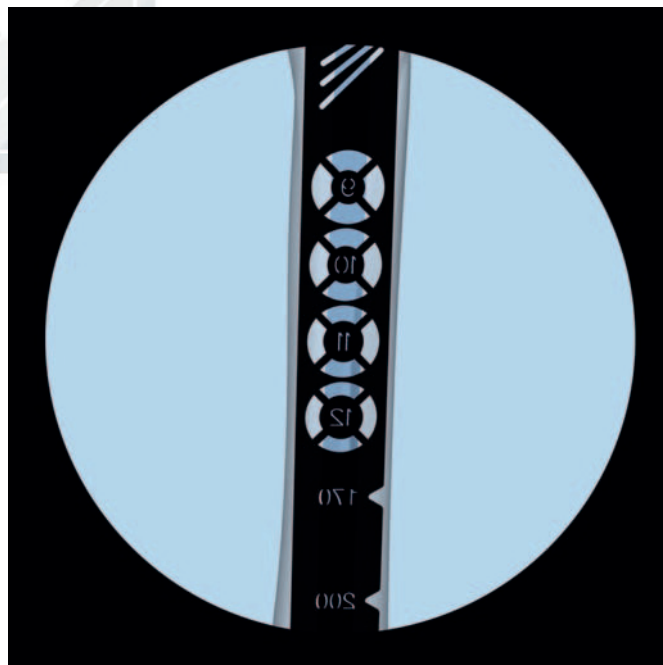

2. Position the patient

The patient with supine position on an extension table or on a radiolucent operating table. Stretch the healthy leg and fixed on the table, preoperative test must be done to ensure free radiolucency.

For unimpeded access to the medullary cavity, abduct the upper part of the body by about 10–15° to the contralateral side (or adduct the affected leg by 10–15°).

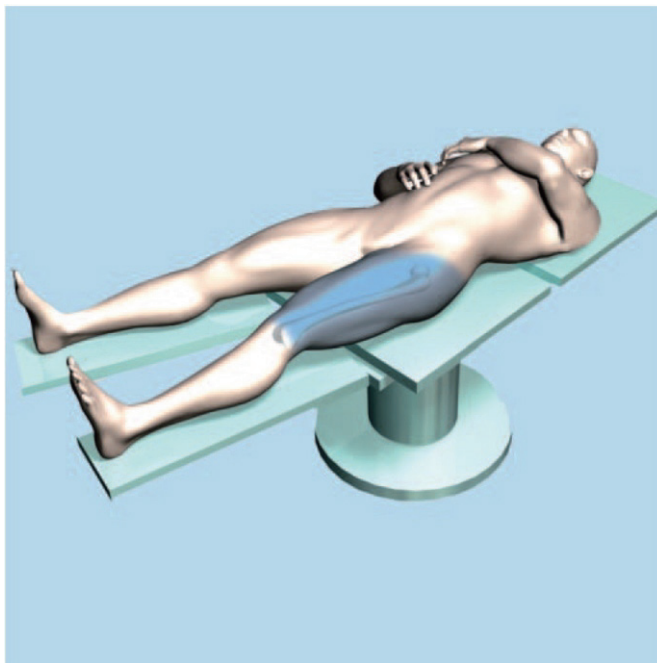

Surgical Approach

1. Palpate the trochanter major

Make a 5 cm incision approximately 5 to 8 cm proximal from the tip of the greater trochanter. Make a parallel incision in the fasciae of the gluteus medius and split the gluteus medius in line with its fibres.

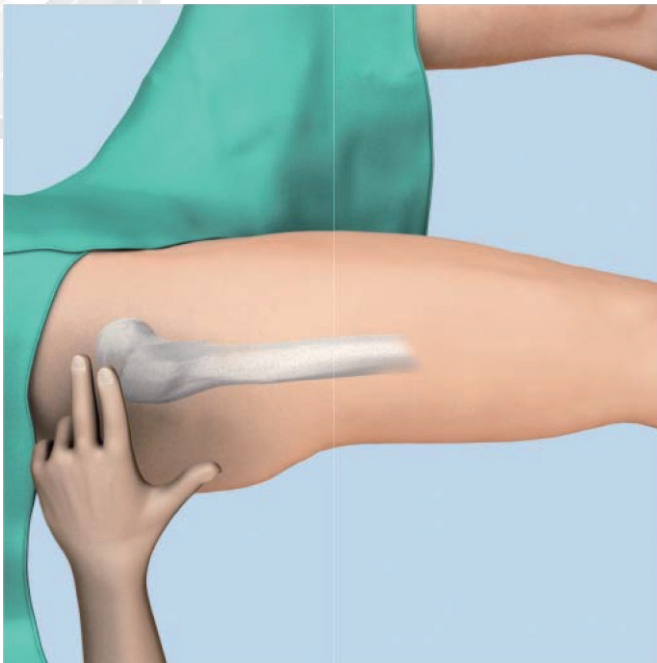

2. Determine nail entry point and direction

In AP view, the nail entry point is usually on the tip or slightly lateral to the tip of the greater trochanter at angle of 5° to the extension of the medullary cavity, as the ML angle of the nail is 5° .

In lateral view, verify whether the position of the guide wire is straight and in the centre of the medullary canal.

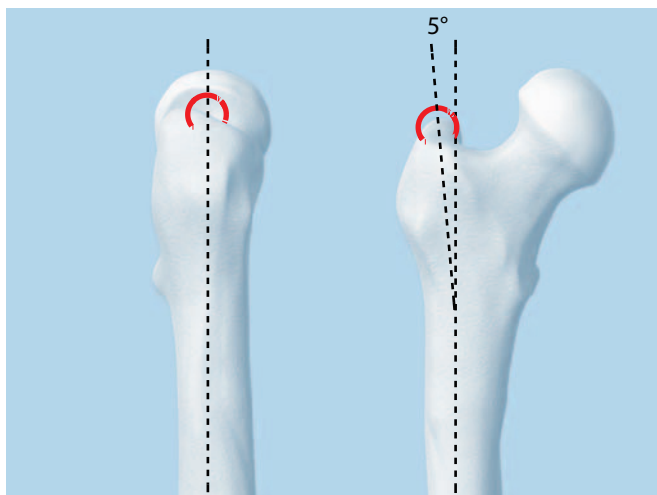

3. Insertion of the guide wire

Insert guide wire through the Protection Sleeve and the Drill Sleeve.

Instruments:

115400018 Protection Sleeve
115400019 Drill Sleeve
115400033 Guide Wire

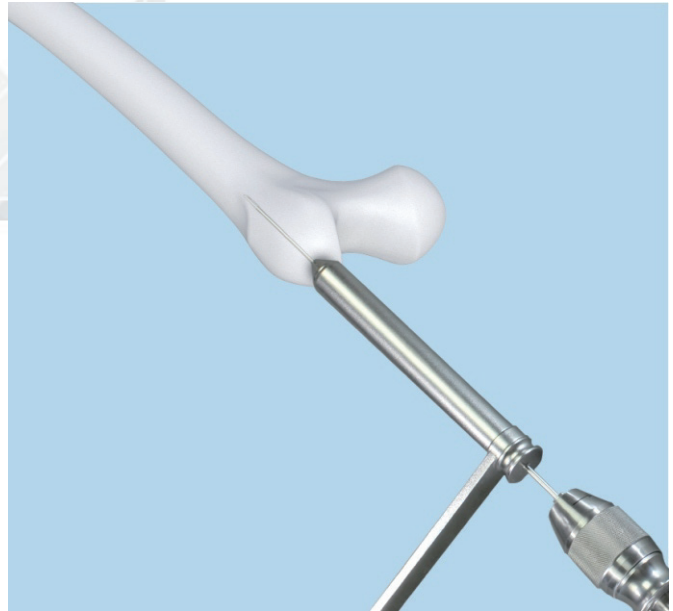

4. Opening of the femur

Insert proximal reamer with universal chunk through the protection sleeve completely to the stop, then remove the protection sleeve, guide wire and proximal reamer.

Or alternatively, use the Tissue Protector (115400026) to spare the soft tissue, open the femur with the Reverse Awl (115400027) manually.

Instruments:

115400016 Universal Chunk with T-Handle
115400025 Proximal reamer
115400026 Tissue Protector
115400027 Awl

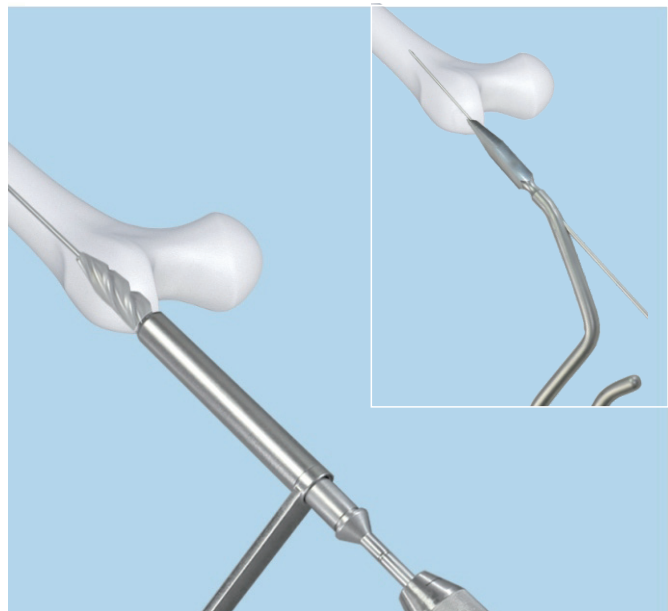

5. Assembly of Instruments and Nail

Guide the Connecting nut(115400014) through the Insertion Handle (115400001) and secure the nail tightly to the insertion handle using the Wrench with T-handle(115400046). The nail diameter has already been determined during surgical preparations.

Instruments:

115400046 Wrench with T-handle
115400014 Connecting nut
115400001 Insertion handle

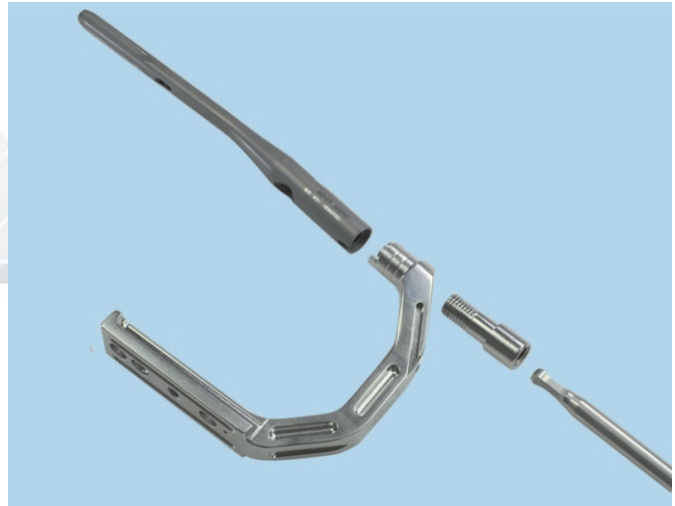

6. Insertion of the nail

Carefully insert the nail manually as far as possible into the femoral opening. Slight twisting hand movements help insertion. If the nail insertion with difficulty, ream the medullary cavity to a diameter that is at least 1mm larger than that of the selected nail, or Impactor (115400029) should be fixed on the insertion handle, then tap gently on the insertion handle.

Note: Avoid unnecessary use of force to prevent loss of reduction or an iatrogenic fracture.



Instruments:

115400029 Impactor
115400032 Slotted Hammer

7.Preparation of guide wire insertion

Fix the Proximal Aiming Arm (115400002) to the insertion handle.

Instrument:

115400002 Proximal Aiming Arm



After the determination of femoral neck screw, select the corresponding protection sleeve for helical blade (115400008) or the protection sleeve for lag screw (115400009), which should be inserted into the corresponding obturator and trocar, finally position the compression nut(115400007) over the protection sleeve.

Insert the assembled protection sleeve through guide hole of proximal aiming arm. Rotating the compression nut(115400007) clockwise and insert the sleeve as far as it reaches the cortex.

Instruments for Lag Screw:

115400009 Protection Sleeve for Lag Screw
115400010 Obturator for Blade
115400006 Distal Trocar
115400007 Compression Nut

Instruments for Helical Blade

115400008 Protection Sleeve for Blade
115400025 Obturator for Blade
115400006 Trocar for distal locking
115400007 Compression Nut

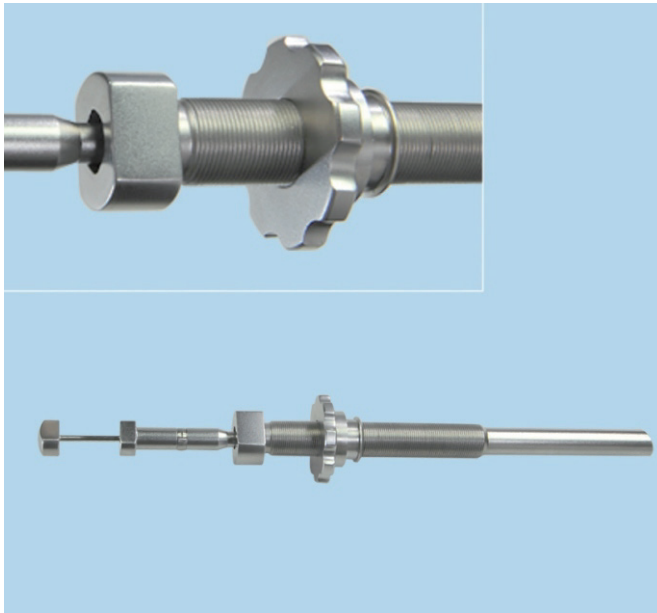

Surgical Technique

Remove trocar and insert guide wire through the drill sleeve into the bone. Verify both direction and position under image intensifier in AP and lateral view. The desired position of the guide wire is as follows:

a: In the AP view, the guide wire tip is at the distance of at least 5mm from the joint, but not more than 10mm.

b: In the AP view, the position of guide wire neck should be in the lower half of the femoral neck.

c: On the lateral view, the guide wire should be positioned in the center of the femoral neck.

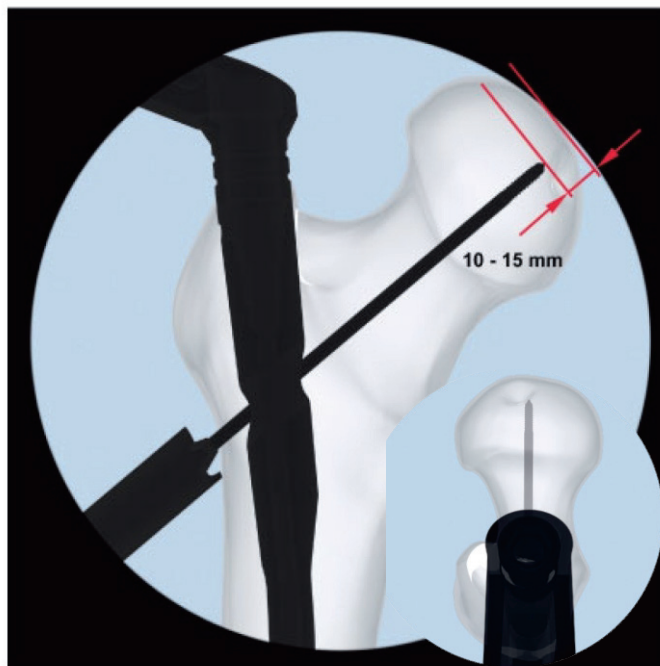

Note: The protection sleeve must be in contact with the bone during the entire blade implantation. Do not tighten the compression nut too firmly as this could impair the precision of the insertion handle and protection sleeve.

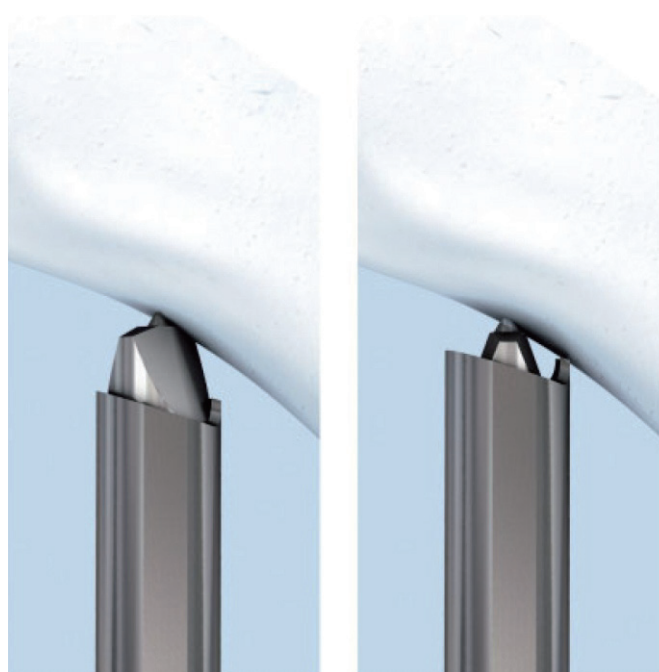

Wrong location

Correct position

8. Measuring length of guide wire

After verify the position of the guide wire in AP and lateral view, using the depth gauge for guide wire (115400034) to measure the length of guide wire by advance it to the protection sleeve. The depth gauge indicates the exact length of the guide wire in the bone ensuring that the position of the lag screw or helical blade will be flush with the tip of the guide wire. If the guide wire's position is subchondral, subtract 5-10mm as the correct length of the lag screw or helical blade.

Instrument:

115400034 Depth gauge for Guide Wire

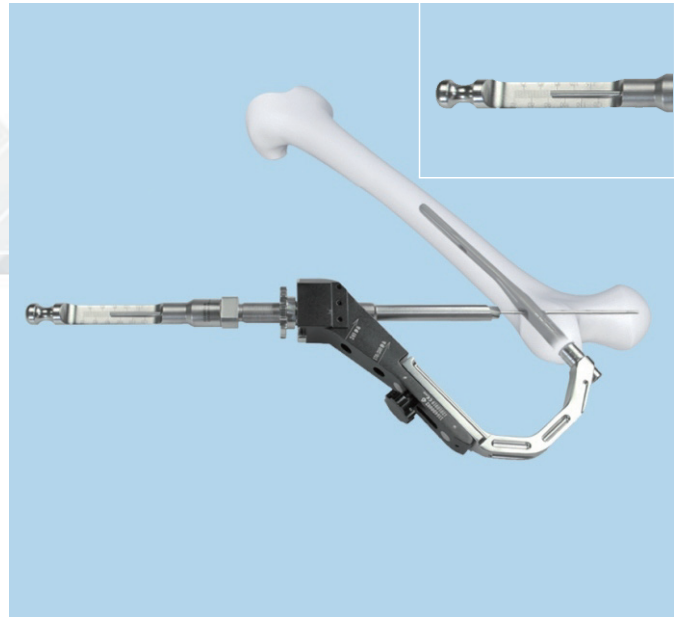

9. Opening lateral femoral cortex

Carefully remove the obturator without changing the position of the guide wire. Insert the Cannulated Drill Bit (115400035) over the guide wire. Drill to the stop, then remove the Cannulated Drill Bit carefully.

Note: If lag screw drilling is applied for femoral neck location, Protection Sleeve for lag screw (115400012) should be used.

Instruments:

115400035 Cannulated Drill Bit for cortex bone $\phi 10.6/\phi 3.2$
115400012 Protection Sleeve for lag screw



10. Enlarge hole for lag screw or helical blade

Set the measured length of the lag screw or helical blade on the Cannulated drill bit by fixing the fixation sleeve in the corresponding position. Insert Cannulated Drill Bit with limit $\phi 10.6/\phi 3.2$ (115400036) over guide wire. Drill to the stop.

Instruments:

- 115400037 Fixation Sleeve SW4.5/ $\phi 3.2$
- 115400036 Cannulated Drill Bit with limit $\phi 10.6/\phi 3.2$
- 115400012 Protection Sleeve for lag screw



Note: Carefully do drilling work if there is difficulty in inserting Cannulated Drill Bit with limit $\phi 10.6/\phi 3.2$ (115400036), and be cautious of the guide wire bent possibility. If Guide wire has been bent to a greater extent, it should be reinserted or replaced by a new guide wire.

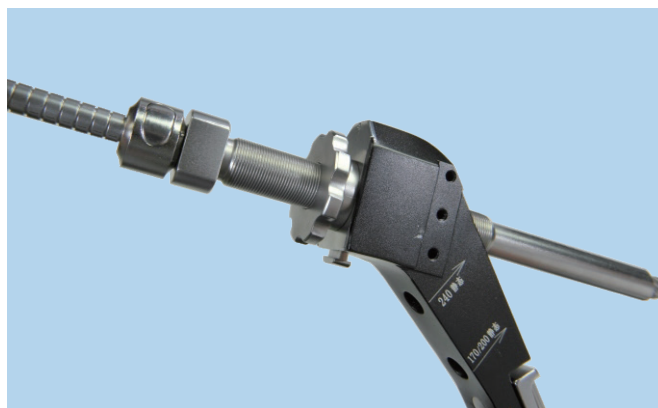

11. Helical blade fixation

11.1 Match helical blade with Screwdriver for PFN Blade.

Helical blade should be prior secured. Insert Screwdriver for PFN Blade(115400038) counter clockwise into helical blade completely with free rotating helical blade tip.

Instrument:

115400038 Screwdriver for PFN Blade

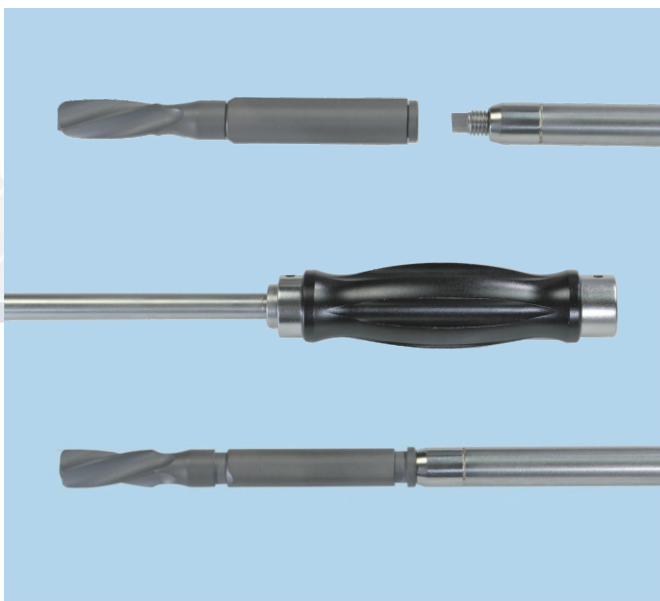

11.2. Insertion of helical blade

Insert both helical blade and screwdriver through the blade protection sleeve over the guide wire.

Tap the end of PFN blade screwdriver manually, advance the helical blade to femur, and stop tapping till the screwdriver touches the distal lateral edge of blade protection sleeve, use image intensification to check the position of the helical blade.

Clockwise insert Impactor till the threads of the helical blade are covered by AP view, which implies the helical blade is tightly secured.

Note: Do not insert the helical blade with excessive force.

Instruments:

115400038 Screwdriver for PFN Blade

115400039 Extractor Connection shaft for blade



12.Lag screw fixation

12.1 Match lag screw with wrench for lag screw

Select the desired length of lag screw, securing the wrench shaft for lag screw (115400054) to lag screw holding shaft(115400053).

Instruments:

115400053 Lag screw holding shaft
115400054 Wrench shaft for lag screw

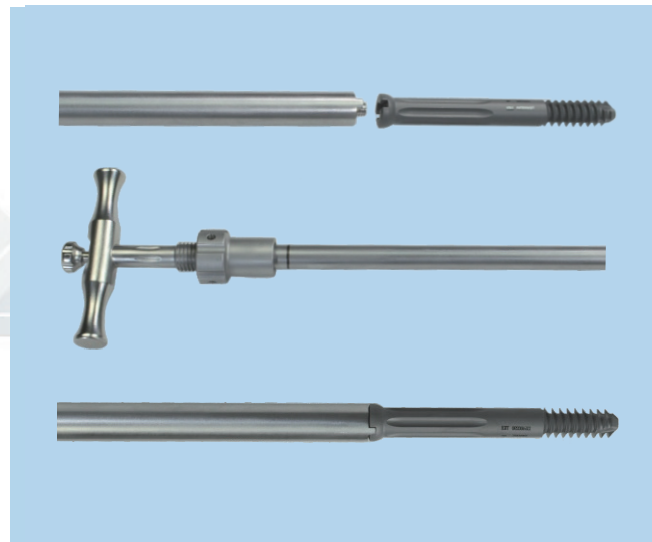

12.2 Insert Lag screw

Insert lag screw till the black marker on lag screw wrench is level with lateral edge of lag screw protection sleeve, and keep lag screw wrench's one flute against to the proximal femur.

If more compression needed for lag screw in surgery, rotate the compression nut and each round will insert 2mm more. Temporary End Cap for the lag screw (115400021) should be inserted into the proximal nail's caudal compression nut prior to distal locking, in order to prevent rotation of lag screw.

After insertion of lag screw has been done, releasing the Lag Screw Holding Shaft, pressing the end of Proximal aiming arm to remove the sleeve system consisting of lag screw protection sleeve, lag screw wrench and guide wire.

Ensure wrench's one caudal slot against to the proximal femur after lag screw seated in the desired depth, otherwise the end cap may not be fixed in the lag screw's slot.

Instrument:

115400021 Temporary End Cap for the lag screw



Note: Black mark on the lag screw wrench must be level with lateral border of the lag screw protection sleeve, otherwise the depth of lag screw insertion will be not appropriate.

13. Distal locking of standard nail

13.1 Static distal locking of standard nail

Perform a stab incision and insert sleeve assembly for distal locking consisting of protection sleeve for distal locking(115400004), obturator for distal locking(115400005) and trocar for distal locking(115400006) through static locking hole on the proximal aiming arm.

Remove the trocar and insert 4.3 Drill Bit(115400041) to break both cortices, then read the length directly on the drill bit.

Or alternatively remove the obturator for distal locking(115400005), then measure the depth with depth gauge for locking screw(115400044).

Note: Static locking holes for 170mm and 200mm nail are the same on the Proximal Aiming Arm. Ensure the stability of the aiming arm prior to distal locking, otherwise distal locking will fail.

Instruments:

115400002	Proximal aiming arm
115400004	Protection sleeve for distal locking
115400005	Obturator for distal locking
115400006	Trocar for distal locking
115400041	4.3 Drill bit
115400044	Depth gauge for locking screw

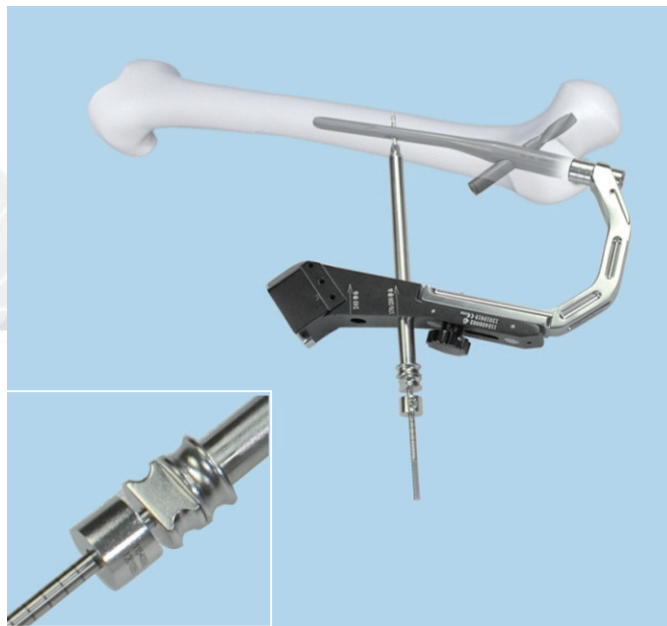

13.2 Dynamic distal locking of standard nail

Remove the proximal aiming arm, and secure the aiming arm for distal locking(115400015) to handle tightly, then proceed as described in point 13.1.

Instruments:

115400004	Protection sleeve for distal locking
115400015	Aiming arm for distal locking



14. Distal locking for long nail

14.1. Fixation of distal aiming arm

Locking of nail longer than 240mm need the help of distal aiming arm. Securing distal aiming connecting shaft (115400055) to the insertion handle (115400001) using connecting nut (115400014).

Determine and secure the hole accordingly to the corresponding distal aiming connecting shaft (115400055), and read the scale. Secure the aiming arm to aiming shaft using targeting device nut for long nail (115400057), ensuring the arc of distal aiming arm match to the arc of proximal femoral nail.

Instruments:

- 115400055 Distal aiming connecting shaft
- 115400063 Connecting nut
- 115400056 Distal targeting device for long nail
- 115400057 Targeting device nut for long nail
- 115400001 Insertion handle



14.2 Distal aiming

First secure the distal outrigger (115400058) to far-end of distal aiming arm using distal outrigger nut for long nail (115400059). Perform an incision and using location shaft (115400062) and obturator (115400022) through distal aiming arm. Drill a location hole on the femur using $\phi 5.2$ drill sleeve and $\phi 5.2$ Drill Bit(115400023) through Location shaft(115400062), then debridement can be done by Flat Drill with T-Handle(115400024). Finally remove $\phi 5.2$ drill bushing and insert location rod(115400061), securing the location rod and distal outrigger(115400058) using U-shaped Stabilizing Spacer(115400060) for the distal locking preparation.

Note: Ensure Location Rod tightly located on the femoral nail, otherwise reinsertion should be done, or alternatively using C-arm fluoroscopy to make the distal locking.



Instruments:

115400058	Distal Outrigger
115400001	Insertion Handle
115400059	Distal Outrigger Nut for long nail
115400060	U-shaped Stabilizing Spacer
115400022	Obturator
115400061	Location Rod
115400062	Location Shaft
115400023	$\phi 5.2$ Drill Bit
115400024	Flat Drill with T-Handle

14.3 Insertion of locking screw

Perform an incision on distal femur and using sleeve system including Protection Sleeve for distal locking(115400004), Obturator for Distal Locking and Distal trocar through guide hole of Distal aiming arm. Insert the locking screw using the screw driver.

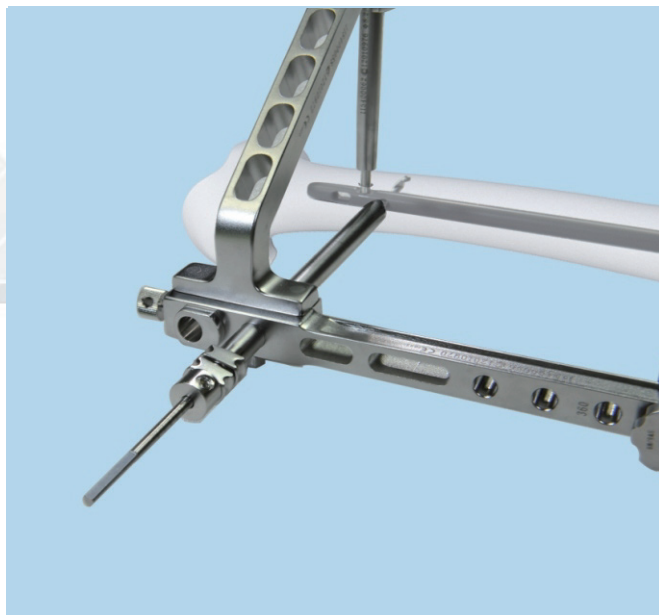

Instruments:

115400004	Protection Sleeve for distal locking
115400005	Obturator
115400041	φ4.3 Drill Bitφ4.3/300mm
115400056	Distal Targeting Device for Long Nail

15. Insertion of end cap

Guide the end cap into the end of femoral nail with help of Guide Wire with Hook φ2.8(115400048), Cannulated Screwdriver for end cap φ2.8/SW4/SW11(115400049) and Cannulated Wrench for end cap SW11(115400050).

Or alternatively using Hexagonal Solid Screwdriver Length 248mm(114400011) to do the insertion.

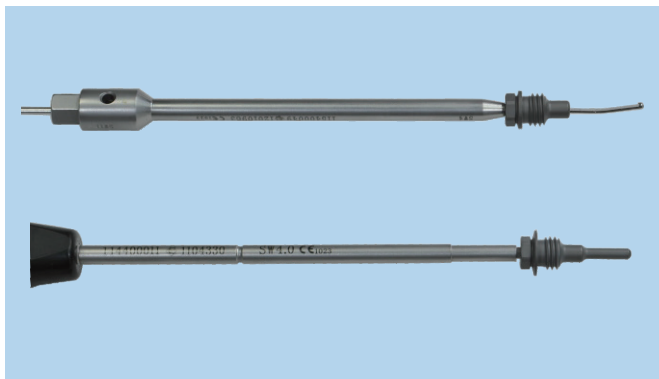

Note: Choose end cap I when use Helical blade, and end cap II when use lag screw.

Instruments:

115400048	Guide Wire with Hook φ2.8
115400049	Cannulated Screwdriver for end cap φ2.8/SW4/SW11
115400050	Cannulated Wrench for end cap SW11
114400011	Hexagonal Solid Screwdriver Length 248mm

Removal of implant

1. Remove helical blade and lag screw

Remove helical blade: Make an incision through the old scar. Ensure the position of helical blade, then secure the helical blade to extractor for blade SW4.5/ ϕ 3.2(115400051)) counter clockwise, finally tap the extractor slightly with slotted hammer (115400032) to remove helical blade.

Instruments:

115400051 Extractor for blade SW4.5/ ϕ 3.2
115400032 Slotted hammer



Remove lag screw: Ensure the position of lag screw. Then secure the wrench shaft for lag screw (115400054) to the lag screw using lag screw holding shaft (115400053), and extract the lag screw with wrench shaft counterclockwise.

Instruments:

115400053 Lag screw holding shaft
115400054 Wrench shaft for lag screw



2. Removal of end cap, locking screw and nail

Ensure the position of nail end through the old incision, and extract the end cap using sw4.0 Hexagonal Screwdriver(115400045), then secure the extractor for nail M8(115400047) to the nail and only then use the screwdriver to remove the last locking screw, now extract the nail with slight hammer blows.

Note: Ensure locking screws have been removed prior to extracting nail.

Remove the locking bolt only after attaching the guide rod to the nail. This prevents the nail from rotating in the bone.



Instruments:

115400045 SW4.0 hexagonal screwdriver
115400047 Extractor for nail M8

Intra and postoperative cleaning

Use the cleaning wire(115400052) for intra and postoperation cleaning of the instrument cannulations.

Instrument:

115400052 Cleaning wire

Nail



P.N	Specification
135406517	Φ 9 × 170 × 130°
135406520	Φ 9 × 200 × 130°
135406524	Φ 9 × 240 × 130°
135406617	Φ 10 × 170 × 130°
135406620	Φ 10 × 200 × 130°
135406624	Φ 10 × 240 × 130°
135406717	Φ 11 × 170 × 130°
135406720	Φ 11 × 200 × 130°
135406724	Φ 11 × 240 × 130°



P.N	Specification
135403536	Φ 9 × 360 × 130° (L)
135403538	Φ 9 × 380 × 130° (L)
135403540	Φ 9 × 400 × 130° (L)
135403542	Φ 9 × 420 × 130° (L)
135403636	Φ 10 × 360 × 130° (L)
135403638	Φ 10 × 380 × 130° (L)
135403640	Φ 10 × 400 × 130° (L)
135403642	Φ 10 × 420 × 130° (L)
135403736	Φ 11 × 360 × 130° (L)
135403738	Φ 11 × 380 × 130° (L)
135403740	Φ 11 × 400 × 130° (L)
135403742	Φ 11 × 420 × 130° (L)
135404536	Φ 9 × 360 × 130° (R)
135404538	Φ 9 × 380 × 130° (R)
135404540	Φ 9 × 400 × 130° (R)
135404542	Φ 9 × 420 × 130° (R)
135404636	Φ 10 × 360 × 130° (R)
135404638	Φ 10 × 380 × 130° (R)
135404640	Φ 10 × 400 × 130° (R)
135404642	Φ 10 × 420 × 130° (R)
135404736	Φ 11 × 360 × 130° (R)
135404738	Φ 11 × 380 × 130° (R)
135404740	Φ 11 × 400 × 130° (R)
135404742	Φ 11 × 420 × 130° (R)

Locking screw



P.N	Specification
135400020	Φ 4.9 × 20
135400024	Φ 4.9 × 24
135400028	Φ 4.9 × 28
135400032	Φ 4.9 × 32
135400036	Φ 4.9 × 36
135400040	Φ 4.9 × 40
135400044	Φ 4.9 × 44
135400048	Φ 4.9 × 48
135400052	Φ 4.9 × 52
135400056	Φ 4.9 × 56
135400060	Φ 4.9 × 60
135400064	Φ 4.9 × 64
135400068	Φ 4.9 × 68
135400072	Φ 4.9 × 72
135400076	Φ 4.9 × 76
135400080	Φ 4.9 × 80

Lag screw



P.N	Specification
135400270	Φ 10.4 × 70
135400275	Φ 10.4 × 75
135400280	Φ 10.4 × 80
135400285	Φ 10.4 × 85
135400290	Φ 10.4 × 90
135400295	Φ 10.4 × 95
135400200	Φ 10.4 × 100
135400205	Φ 10.4 × 105
135400210	Φ 10.4 × 110
135400215	Φ 10.4 × 115
135400220	Φ 10.4 × 120

Helical blade



P.N	Specification
135400375	Φ 10.4 × 75
135400380	Φ 10.4 × 80
135400385	Φ 10.4 × 85
135400390	Φ 10.4 × 90
135400395	Φ 10.4 × 95
135400300	Φ 10.4 × 100
135400305	Φ 10.4 × 105
135400310	Φ 10.4 × 110
135400315	Φ 10.4 × 115
135400320	Φ 10.4 × 120

End cap



P.N	Specification
135400101	5
135400102	10
135400103	15

End cap



P.N	Specification
135400104	5
135400105	10
135400106	15

Implant information

115400001

Insertion handle

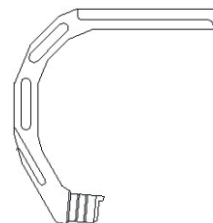

115400002

Proximal aiming arm

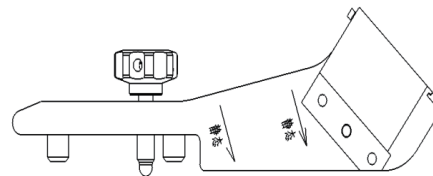

115400003

Buttress Nut for Proximal Aiming Arm

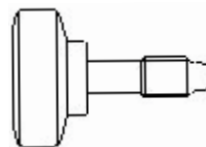

115400004

Protection sleeve for distal locking

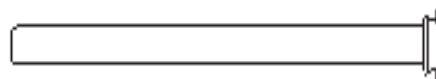

115400005

Obturator

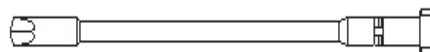

115400006

Distal Trocar



115400007

Compression Nut

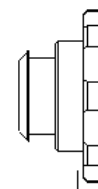

115400008

Protection Sleeve for blade



115400009

Protection Sleeve for lag screw



Implant information

- 115400010 Obturator for Blade
- 115400011 Obturator for Lag Screw
- 115400012 Protection Sleeve for lag screw
- 115400013 Trocar
- 115400014 Connecting nut
- 115400015 Aiming arm for distal locking
- 115400016 Universal Chunk with T-Handle
- 115400017 Radiographic Ruler
- 115400018 Protection Sleeve
- 115400019 Drill Sleeve
- 115400020 Ø5.2 Protection Drill Sleeve

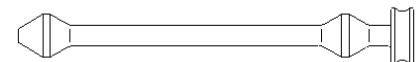
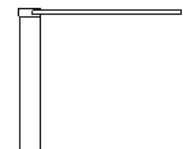
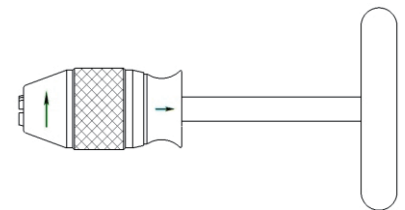
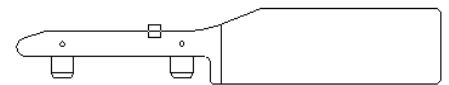
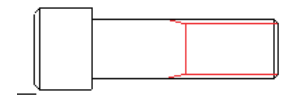
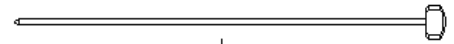
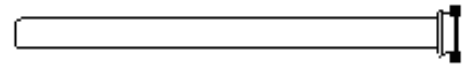
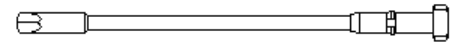
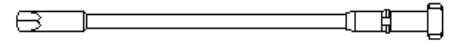

Implant information

115400021 Temporary End Cap for the lag screw

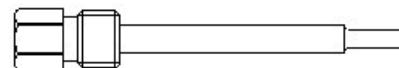

115400022 Obturator

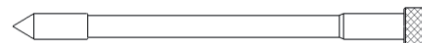

115400023 ϕ 5.2 Drill Bit

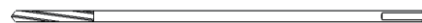

115400024 Flat Drill with T-Handle



115400025 Proximal reamer



115400026 Tissue Protector

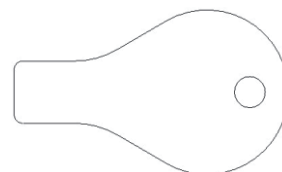

115400027 Awl



115400028 Ball head needle



115400029 Impactor

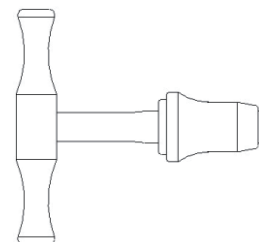

115400030 Quick Connection T-Handle

115400031 wrench

Implant information

- 115400032 Slotted Hammer
- 115400033 Guide Wire
- 115400034 Depth gauge for Guide Wire
- 115400035 Cannulated Drill Bit for cortex bone $\phi 10.6/\phi 3.2$
- 115400036 Cannulated Drill Bit with limit $\phi 10.6/\phi 3.2$
- 115400037 Fixation Sleeve SW4.5/ $\phi 3.2$
- 115400038 Screwdriver for PFN Blade
- 115400039 Extractor Connection shaft for blade
- 115400040 Blade nail nails against a wrench
- 115400041 $\phi 4.3$ Drill Bit
- 115400042 $\phi 4.5$ Drill Stop
- 115400043 Pin Wrench

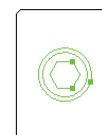
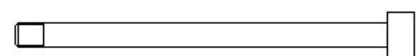
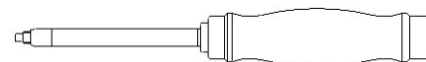
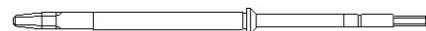
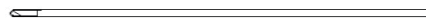
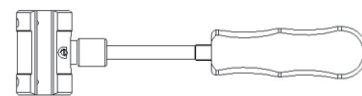

Implant information

115400044 Depth gauge for locking screw



115400045 Screwdriver, hexagonal

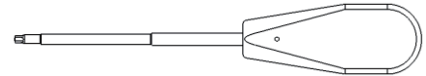

115400046 Wrench with T-handle



115400047 Extractor for Nail

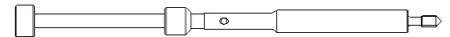

115400048 Guide Wire with Hook ϕ 2.8



115400049 Cannulated Screwdriver for end cap ϕ 2.8/SW4/SW11

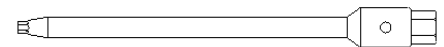

115400050 Cannulated Wrench for end cap SW11



115400051 Extractor for Blade

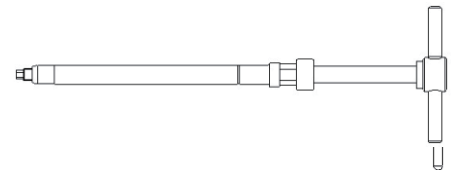

115400052 Cleaning Wire



115400053 Lag screw holding shaft

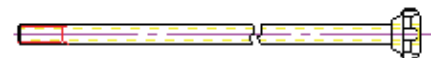

115400054 Wrench shaft for lag screw

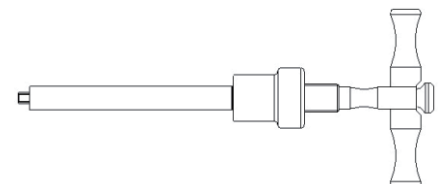

115400055 Distal aiming connecting shaft

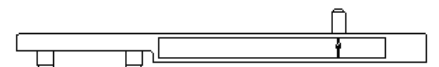

Implant information

115400056 Distal targeting device for long nail

115400057 Targeting device nut for long nail

115400058 Distal Outrigger

115400059 Distal Outrigger Nut for long nail

115400060 U-shaped Stabilizing Spacer

115400061 Location shaft

115400062 Location Sleeve

115400063 Handle connecting nut

114400011 Hexagonal Solid Screwdriver Length 248mm

